

UC

● Cad Insertion Point

Patented
 Max. 150°C

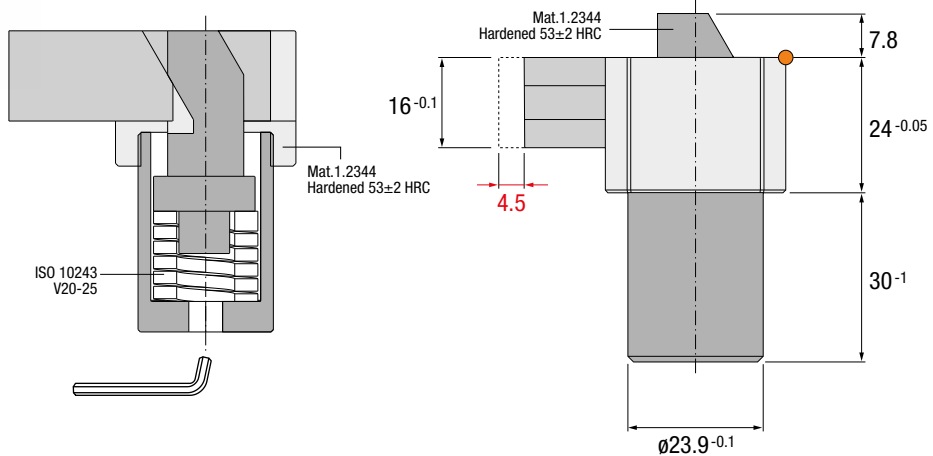

Ref.
UC.325445

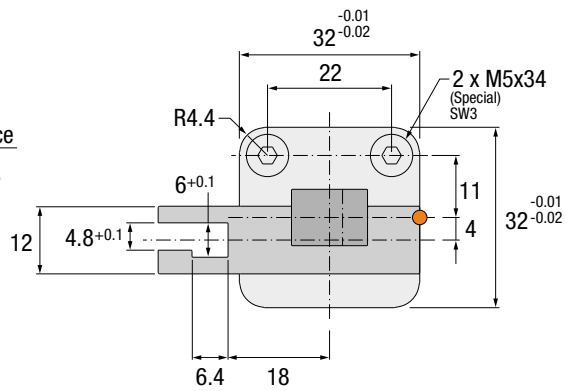
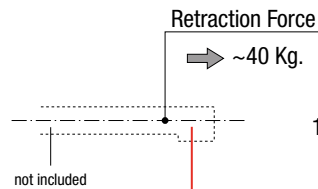

IMPORTANT !
 Option for machining keyway.
 Posibilidad de mecanizado antigiro.
 Möglichkeit zur Herstellung einer Aussparung.
 Possibilità di lavorazione antigiro.
 Possibilidade de maquinação anti-rotação.
 Possibilitè d'indexer la broche.

IMPORTANT !
 Standard stroke of 4.5mm.
 Recorrido estándar de 4.5mm.
 Standard Hub 4.5mm.
 Corsa del asta 4.5mm.
 Curso standard de 4.5mm.
 Course standard de 4.5mm.

Installation Guidelines

Consejos de Instalación · Richtlinien zur Installation · Consigli di Installazione · Instruções de Instalação · Mode d'Installation

