

EXTERNAL SYNCHRONIZED PLATES

ES Sincronizador de Placas Externo DE Externe Plattensynchronisation
 IT Sincronizzatore di Piastre Esterno PT Sincronizador Chapas Externo Externa FR Synchronisation Mouvement Plaques

● Cad Insertion Point

EZ

Max. 150°C

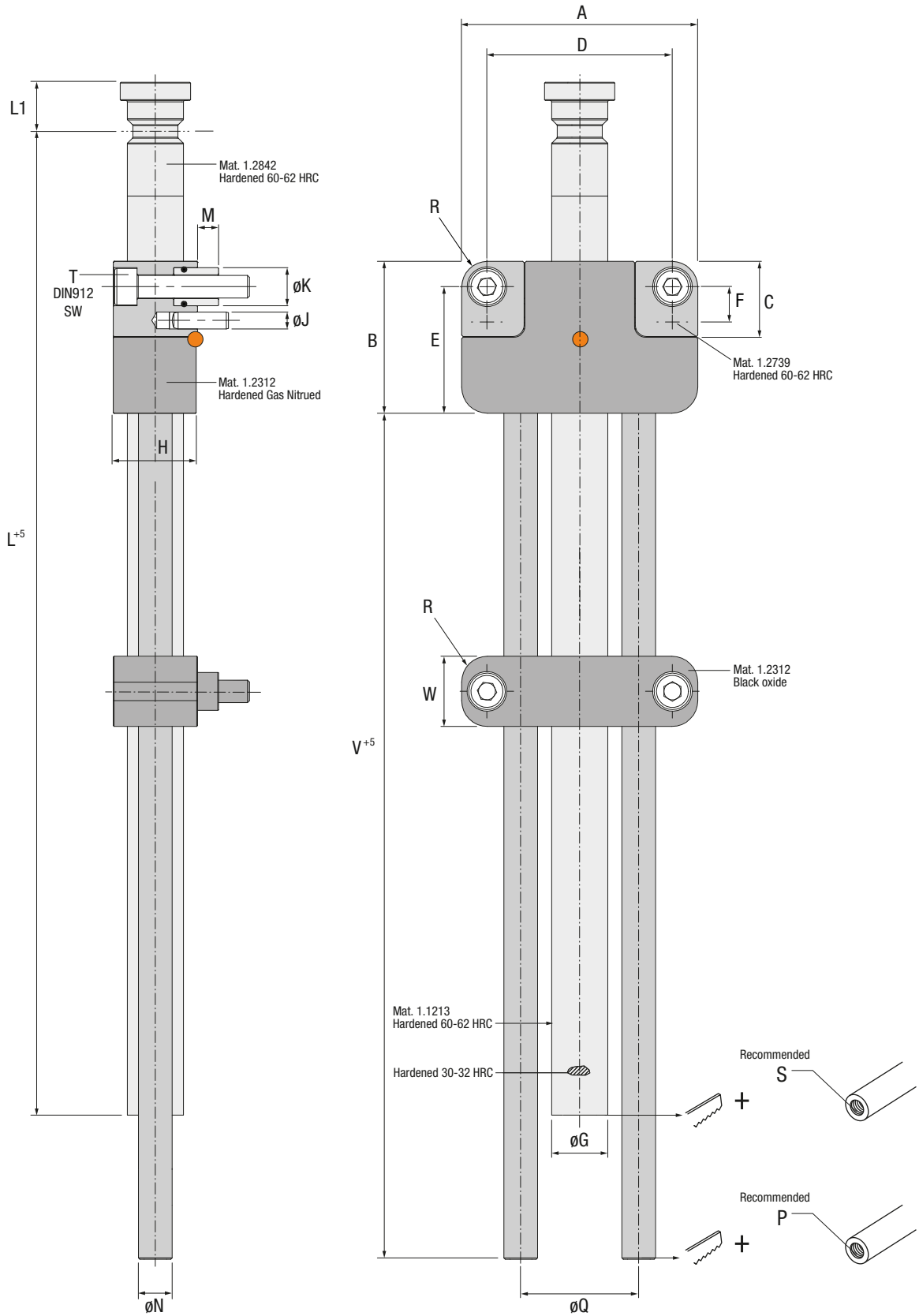

Ref.	A	B	C	D	E	F	G	H	J	K	L	L1	M	N	P	Q	R	S	T	V
EZ.140608	62	40	20	48	33	9	14	22	Ø4x14 (DIN6325)	10.5	348	13	5.5	8	M5	30	7.2	M8	M6x30	300
EZ.200812	84	54	27	66	45	12	20	30	Ø6x20 (DIN7979)	13.5	348	17.5	7.5	12	M8	42	9.2	M12	M8x40	300
EZ.321220	126	84	42	102	72	20	32	46	Ø10x30 (DIN7979)	18.5	530	27	11.5	20	M12	65	12.5	M16	M12x65	450
EZ.501625	174	120	60	140	103	26	50	64	Ø12x40 (DIN7979)	25	530	40	15.5	25	M16	92	17	M24	M16x90	450

INSTALLATION GUIDELINES

ES Consejos de Instalación DE Richtlinien zur Installation
 IT Consigli di Installazione PT Instruções de Instalação FR Mode d'Installation



EZ

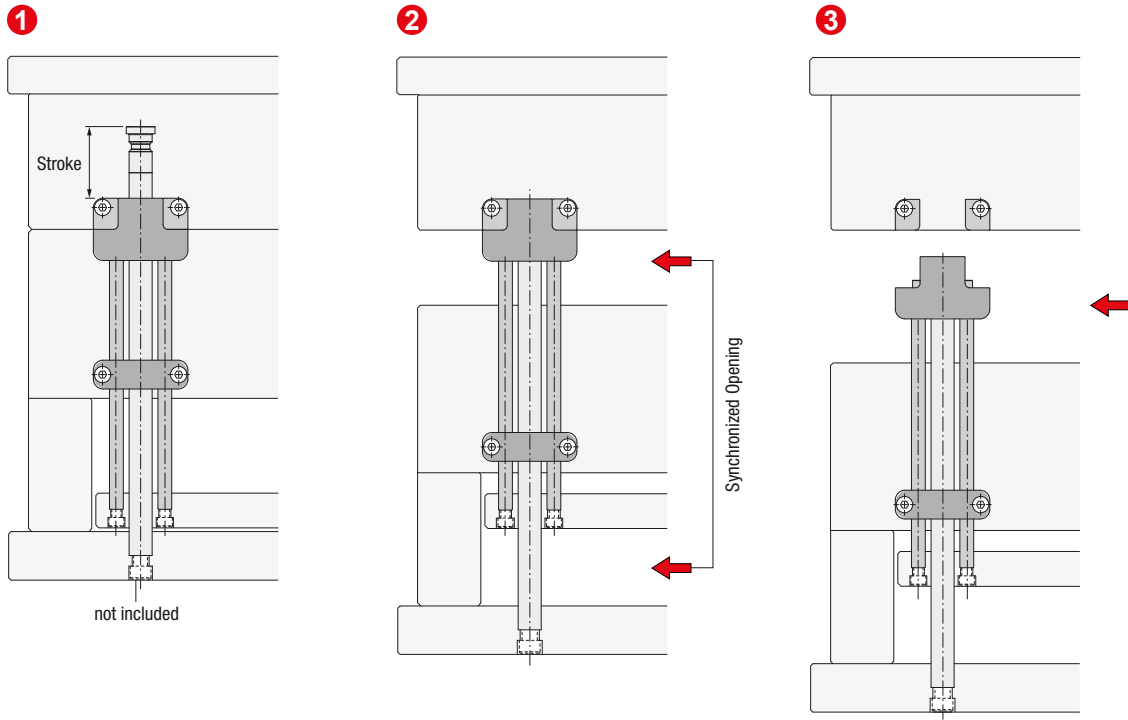

Max. 150°C

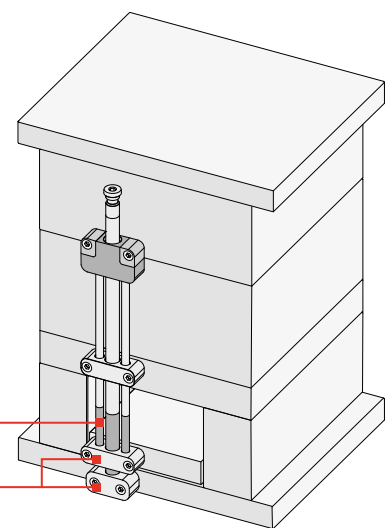

	W	Min. Stroke	Max. Stroke	RF (N)	SW
	20	4	250	4.000	5
	25	5	250	9.000	6
	42	8	375	20.000	10
	60	10	375	40.000	14