

INSTALLATION GUIDELINES

ES Consejos de Instalación DE Richtlinien zur Installation
 IT Consigli di Installazione PT Instruções de Instalação FR Mode d'Installation



EX

THREE PLATE MOLD APPLICATION

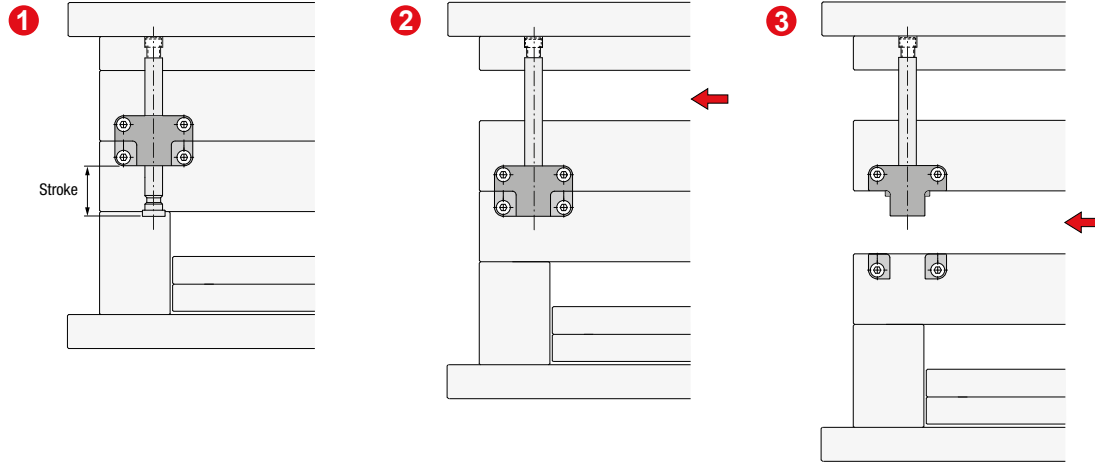

DOUBLE EJECTION APPLICATION

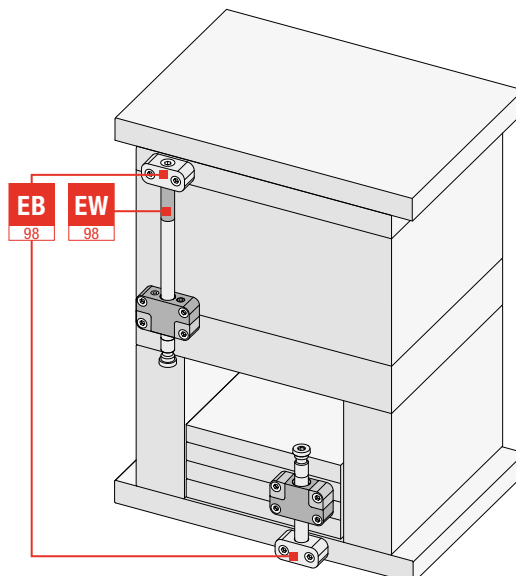
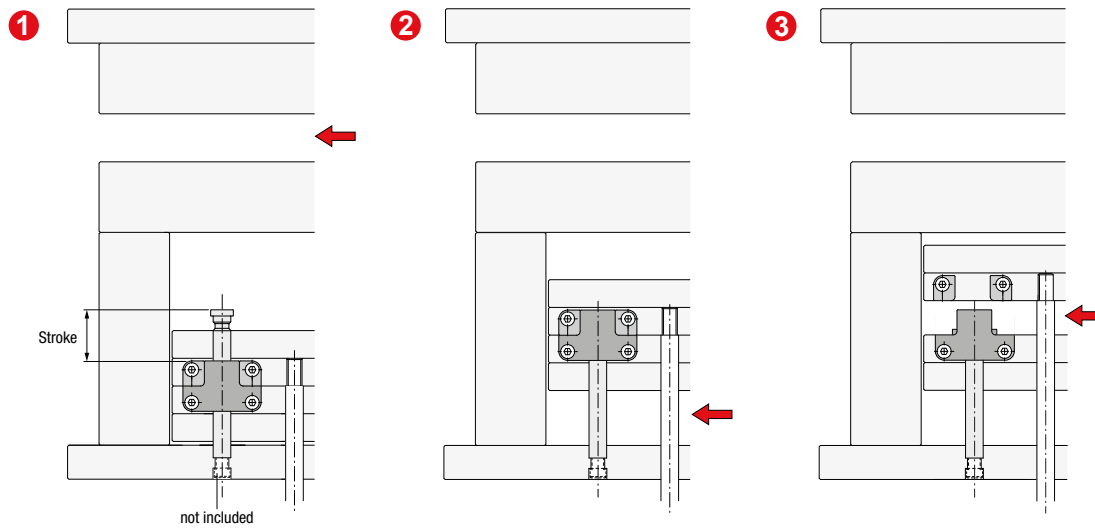

	Min. Stroke	Max. Stroke	RF (N)	SW
	4	250	4.000	5
	5	250	9.000	6
	8	375	20.000	10
	10	375	40.000	14