

Nominal Pressure, static · 250bar (3600PSI)

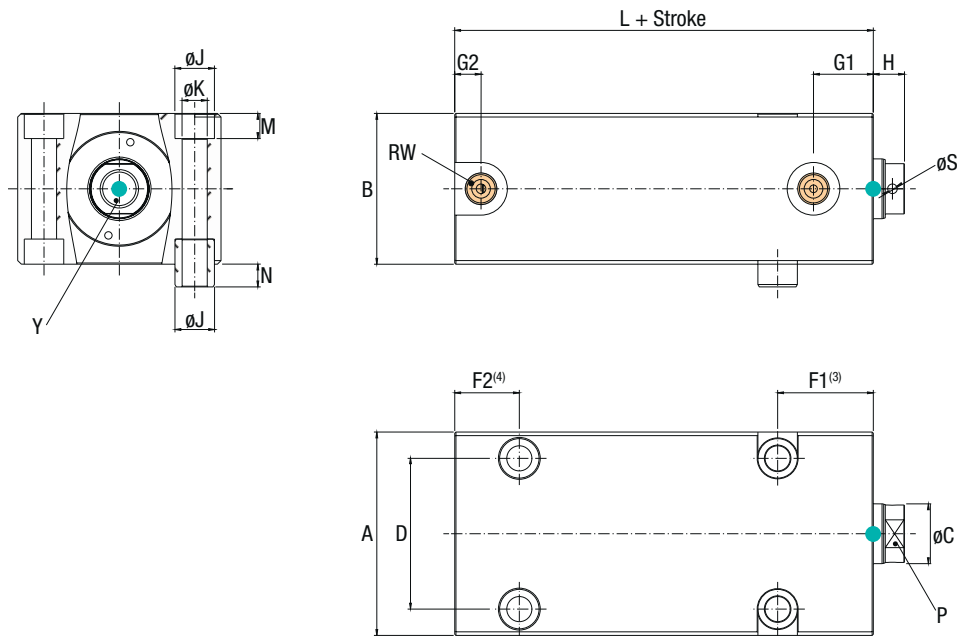

**PURGE / SENSOR<sup>(2)</sup> POSITION ORDERING**  
**SOLICITUD DE POSICIÓN PURGA / SENSOR<sup>(2)</sup>**  
**SPURGO / SENSORE<sup>(2)</sup> INDICARE POSIZIONE**  
**POSIÇÃO DE PURGAS / SENSORES<sup>(2)</sup>**

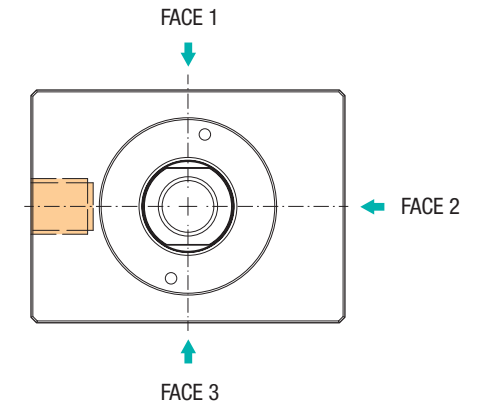

**P0:** Without Purge  
**Px:** Purge in FACE x  
 Replace x by FACE number

**P0:** Sin Purga  
**Px:** Purga en la FACE x  
 Sustituir x por el número de FACE

**P0:** Ohne Säuberung  
**Px:** Säuberung an FLÄCHE x  
 x ersetzen mit FLÄCHEN-Nummer

**P0:** Senza Spurgo  
**Px:** Spurgo FACE x  
 Sostituire x con il numero della FACE

**P0:** Sem Purgas  
**Px:** Purga na FACE x  
 Substituir x pelo numero da FACE

**SENSOR AND SENSOR ASSEMBLY KIT MUST BE ORDERED SEPARATELY / EL SENSOR Y EL KIT DE MONTAJE DEL SENSOR DEBEN PEDIRSE POR SEPARADO / SENSOR UND SENSORBAUSATZ MÜSSEN SEPARAT BESTELT WERDEN / IL KIT DEI SENSORI E SENSORI DEVONO ESSERE ORDINATI SEPARATAMENTE / SENSOR E KIT DE MONTAGEM TEM DE SER ENCOMENDADOS EM SEPARADO**

**S0:** Without Sensor  
**Sx:** Sensor in FACE x  
 Replace x by FACE number

**S0:** Sin Sensor  
**Sx:** Sensor en la FACE x  
 Sustituir x por el número de FACE

**S0:** Ohne Sensor  
**Sx:** Sensor an FLÄCHE x  
 x ersetzen mit FLÄCHEN-Nummer

**S0:** Senza Sensore  
**Sx:** Sensore FACE x  
 Sostituire x con il numero della FACE

**S0:** Sem Sensor  
**Sx:** Sensor na FACE x  
 Substituir x pelo numero da FACE

● 3D Insertion Reference

HOW TO ORDER / FORMATO DE PEDIDO / WIE MAN BESTELT / COME ORDINARE / COMO ENCOMENDAR

mm

Reference: **A0CW025-090P2S1**

TYPE	OPERATION MODE	FIXING STYLE	PISTON $\varnothing$	STROKE <sup>(1)</sup>		PURGE <sup>(2)</sup>	SENSOR <sup>(2)</sup>	A	B	C	D	F1 <sup>(3)</sup>	F2 <sup>(4)</sup>	G1	G2	H	J	K	L	M	N	P	RW	S	Y
				MIN.	MAX.																				
A	0	CW	016	010	100	P0 Px	S0 Sx	60	35	10	40	30 <sup>(3)</sup>	27.5	18	15	8	10.5	6.5	43	6.5	5.5	8	1/4"	-	M6x12
			025	010	120			65	45	16	50	33	30	20	13	10	13.5	8.5	48	8.5	7.5	13	1/4"	3	M10x15
			032	010	150			75	55	20	55	38 <sup>(3)</sup>	28	23	11	12	16.5	10.5	51	10.5	9.5	17	1/4"	4	M12x15
			040	020	160			85	63	25	63	40	28	25	11	13	16.5	10.5	55	10.5	9.5	21	1/4"	4	M16x25
			050	020	180			100	75	32	76	44	30	27	13	14	18.5	13	65	13	11	26	1/4"	5	M20x30
			063	020	180			125	95	40	95	50	41	28	16	18	25	17	72	17	15	32	1/2"	5	M24x35
			080	080	180			160	120	50	120	60	46	37	17	22	31	21	84	21	19	41	1/2"	5	M30x50
			100	080	180			200	150	60	158	64	54	40	20	22	37	25	90	25	23	52	1/2"	5	M36x60

STROKE<sup>(1)</sup>: Can be ordered in multiples of 10mm, between Min. and Max. values.  
 STROKE<sup>(1)</sup> / RECORRIDO: Se puede pedir en múltiples de 10mm., entre los valores Min. y Max.  
 STROKE<sup>(1)</sup> / HUB: Kann in mehreren 10mm Varianten bestellt werden, zwischen min. und max.  
 STROKE<sup>(1)</sup> / CORSA: Può essere ordinata in multipli di 10mm., tra i valori Min. e Max.  
 STROKE<sup>(1)</sup>: Disponível em múltiplos de 10mm, entre os valores Min. e Max.

PURGE / SENSOR<sup>(2)</sup> POSITION ORDERING: Replace x by FACE number.  
 SOLICITUD DE POSICIÓN PURGA / SENSOR<sup>(2)</sup>: Sustituir x por el número de FACE.  
 SÄUBERUNG / SENSOR(2) POSITIONEN BESTELLEN: x ersetzen mit Flächen-Nummer.  
 SPURGO / SENSORE<sup>(2)</sup> INDICARE POSIZIONE: Sostituire x con il numero della FACE.  
 LOCALIZAÇÃO DA PURGA / SENSOR<sup>(2)</sup>: Substituir x pelo numero da FACE.

<sup>(3)</sup> Piston  $\varnothing$ 16 & Stroke=10  $\Rightarrow$  F1 = 28  
<sup>(3)</sup> Piston  $\varnothing$ 32 & Stroke=10  $\Rightarrow$  F1 = 36

<sup>(4)</sup> PISTON  $\varnothing$ 16 & Stroke  $\leq$  70  $\Rightarrow$  F2 = -  
<sup>(4)</sup> PISTON  $\varnothing$ 25,  $\varnothing$ 32,  $\varnothing$ 40,  $\varnothing$ 50,  $\varnothing$ 63,  $\varnothing$ 80,  $\varnothing$ 100 & Stroke  $\leq$  90  $\Rightarrow$  F2 = -