

Max. 250 bar (3600PSI)

Max. 180°C (356°F)

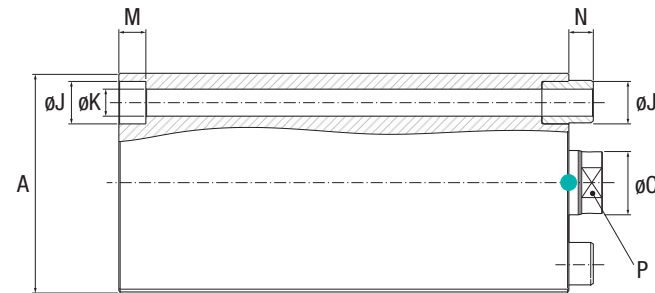

PURGE / SENSOR (2) POSITION ORDERING
SOLICITUD DE POSICIÓN PURGA / SENSOR (2)
SPURGO / SENSORE (2) INDICARE POSIZIONE
POSIÇÃO DE PURGAS / SENSORES (2)
POISTION DE LA PURGE / DÉTECTEUR (2)

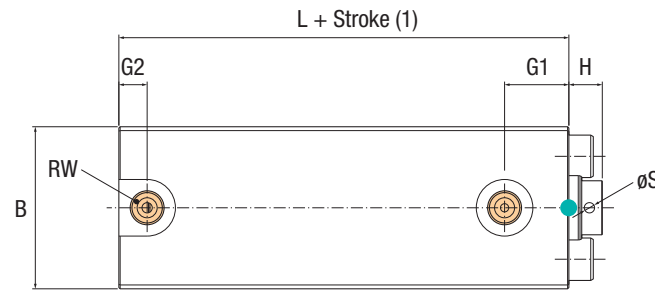
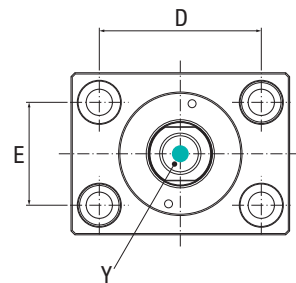
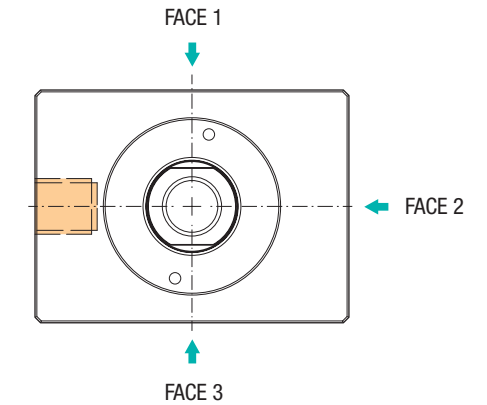

P0: Without Purge Px: Purge in FACE x Replace x by FACE number	P0: Sin Purga Px: Purga en la FACE x Sustituir x por el número de FACE	P0: Ohne Säuberung Px: Säuberung an FLÄCHE x x ersetzen mit FLÄCHEN-Nummer	P0: Senza Spurgo Px: Spurgo FACE x Sostituire x con il numero della FACE	P0: Sem Purgas Px: Purga na FACE x Substituir x pelo numero da FACE	P0: Sans purge Px: Purge sur la face x Substituer x par le numéro de la face
--	--	--	--	---	--

SENSOR AND SENSOR ASSEMBLY KIT MUST BE ORDERED SEPARATELY / EL SENSOR Y EL KIT DE MONTAJE DEL SENSOR DEBEN PEDIRSE POR SEPARADO / SENSOR UND SENSORBAUSATZ MÜSSEN SEPARAT BESTELLT WERDEN / IL KIT DEI SENSORI E SENSORI DEVONO ESSERE ORDINATI SEPARATAMENTE / SENSOR E KIT DE MONTAGEM TEM DE SER ENCOMENDADOS EM SEPARADO / LE DÉTECTEUR ET LE KIT DE MONTAGE DOIVENT ÊTRE COMMANDÉ SÉPARÉMENT

S0: Without Sensor Sx: Sensor in FACE x Replace x by FACE number	S0: Sin Sensor Sx: Sensor en la FACE x Sustituir x por el número de FACE	S0: Ohne Säuberung Sx: Säuberung an FLÄCHE x x ersetzen mit FLÄCHEN-Nummer	S0: Senza Sensore Sx: Sensore FACE x Sostituire x con il numero della FACE	S0: Sem Sensor Sx: Sensor na FACE x Substituir x pelo numero da FACE	S0: Sans détecteur Sx: Détecteur sur la Face x Substituer x par le numéro de la face
--	--	--	--	--	--

3D Insertion Reference

HOW TO ORDER / FORMATO DE PEDIDO / WIE MAN BESTELT / COME ORDINARE/COMO ENCOMENDAR /COMMENT COMMANDER

mm

A	0	AW	025	-	090	P2	S1	Reference: A0AW025-090P2S1																
TYPE	OPERATION MODE	FIXING STYLE	PISTON Ø	STROKE ±0.5 (1)		PURGE (2)	SENSOR (2)	A	B	C	D	E	G1	G2	H ±0.5	J	K	L	M	N	P	RW	S	Y
				MIN.	MAX.																			
A	0	AW	016	010	100	P0 Px	S0 Sx	60	35	10	40	22	18	15	8	10.5	6.5	43	6.5	5.5	8	1/4"	-	M6x12
			025	010	120			65	45	16	50	30	20	13	10	13.5	8.5	48	8.5	7.5	13	1/4"	3	M10x15
			032	010	150			75	55	20	55	35	23	11	12	16.5	10.5	51	10.5	9.5	17	1/4"	4	M12x15
			040	020	160			85	63	25	63	40	25	11	13	16.5	10.5	55	10.5	9.5	21	1/4"	4	M16x25
			050	020	180			100	75	32	76	45	27	13	14	18.5	13	65	13	11	26	1/4"	5	M20x30
			063	020	180			125	95	40	95	65	28	16	18	25	17	72	17	15	32	1/2"	5	M24x35
			080	020	180			160	120	50	120	80	37	17	22	31	21	84	21	19	41	1/2"	5	M30x50
			100	020	180			200	150	60	158	108	40	20	22	37	25	90	25	23	52	1/2"	5	M36x60

STROKE (1)
 Can be ordered in multiples of 10mm, between Min. and Max. values.
 Se puede pedir en múltiplos de 10mm., entre los valores Min. y Max.
 Kann in mehreren 10mm Varianten bestellt werden, zwischen min. und max.
 Può essere ordinata in multipli di 10mm., tra i valori Min. e Max.
 Disponível em múltiplos de 10mm, entre os valores Min. e Max.
 Disponible en multiple de 10mm, entre les valeurs mini et maxi.

PURGE / SENSOR(2)
 Replace x by FACE number.
 Sustituir x por el número de FACE.
 x ersetzen mit Flächen-Nummer.
 Sostituire x con il numero della FACE.
 Substituir x pelo numero da FACE.
 Substituer x par le numéro de la Face.