

TURNING KEY

ES Llave de Giro DE Montageschlüssel
IT Chiave per Aggiornamento PT Chave de Rotação FR Clé de Changement d'Information

● Cad Insertion Point

TK



TURNING KEY SUPPORT

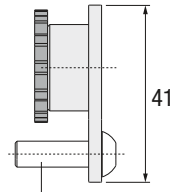

M6x20
DIN7380

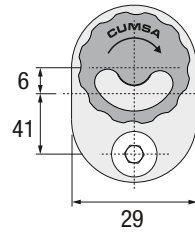

TURNING KEY

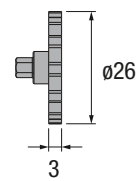

Ref.

TK.412903

Warehouse and transport position

Posición en almacén y durante el transporte
Werkzeuginlager- und Transportposition
Posizione in magazzino e durante il trasporto
Posição de molde em armazém
Position lors du stockage et du transport

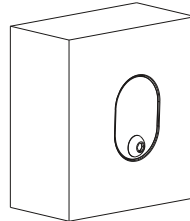

Molding position

Posición en producción
Werkzeugpositionierung
Posizione di stampaggio
Posição de molde em injeção
Position lors de la production

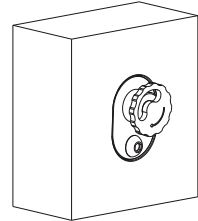

Installation Guidelines

Consejos de Instalación · Richtlinien zur Installation · Consigli di Installazione · Instruções de Instalação · Mode d'Installation

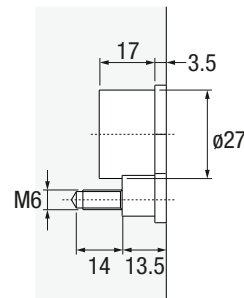
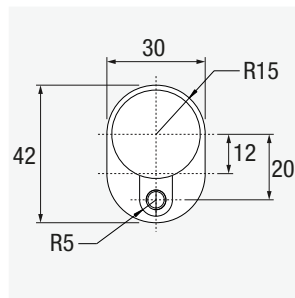

CT

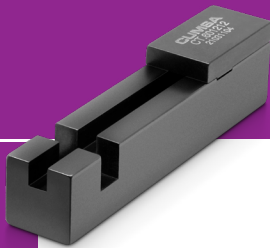

SHAFT CUTTING JIG

ES Util de Corte para la Varilla DE Einstellungsrichtung Zum Ablängen
IT Utensile per Taglio Asta PT Gabarito para Corte de Veio de Transmissão FR Outil de Coupe Pour les Tiges

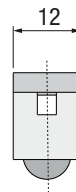
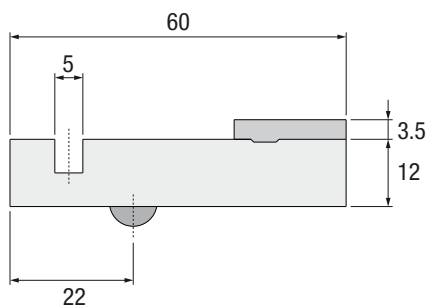

Ref.

CT.601212

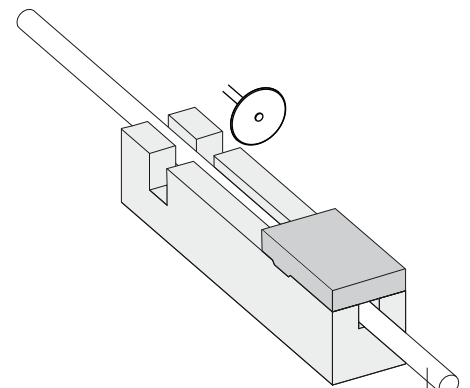

FLEXIBLE
SHAFT

TRACEABILITY



TRACEABILITY

