

**MS41**

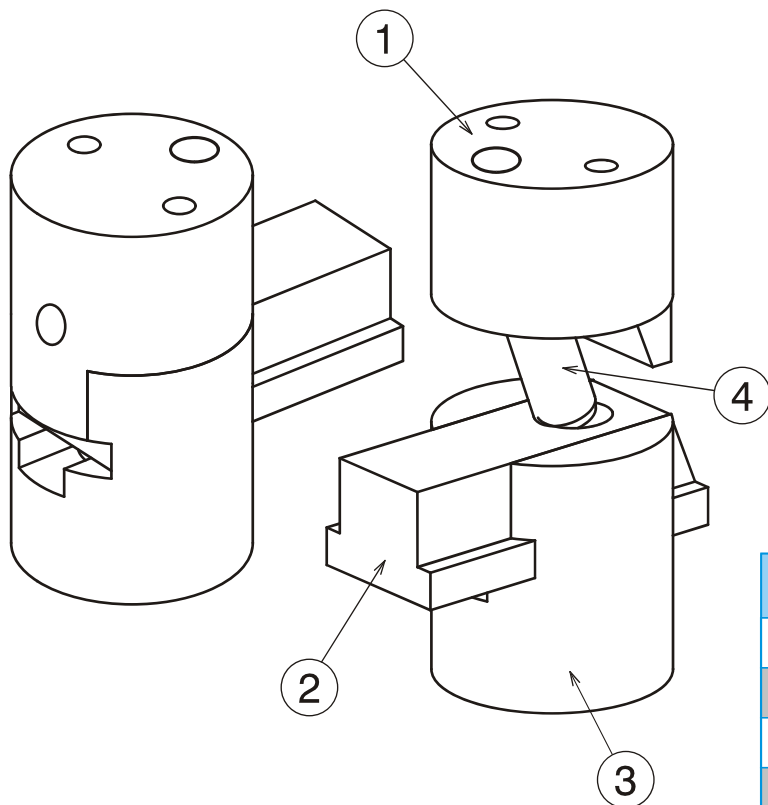

Część Part	Mat.	Obróbka cieplna Treatment
1	1.2312	Azotowane / Nitrided
2	1.2343	Hartowane / Hardened HRC 52-54
3	1.2312	Azotowane / Nitrided
4	C53	Hartowane / Hardened HRC 61-64

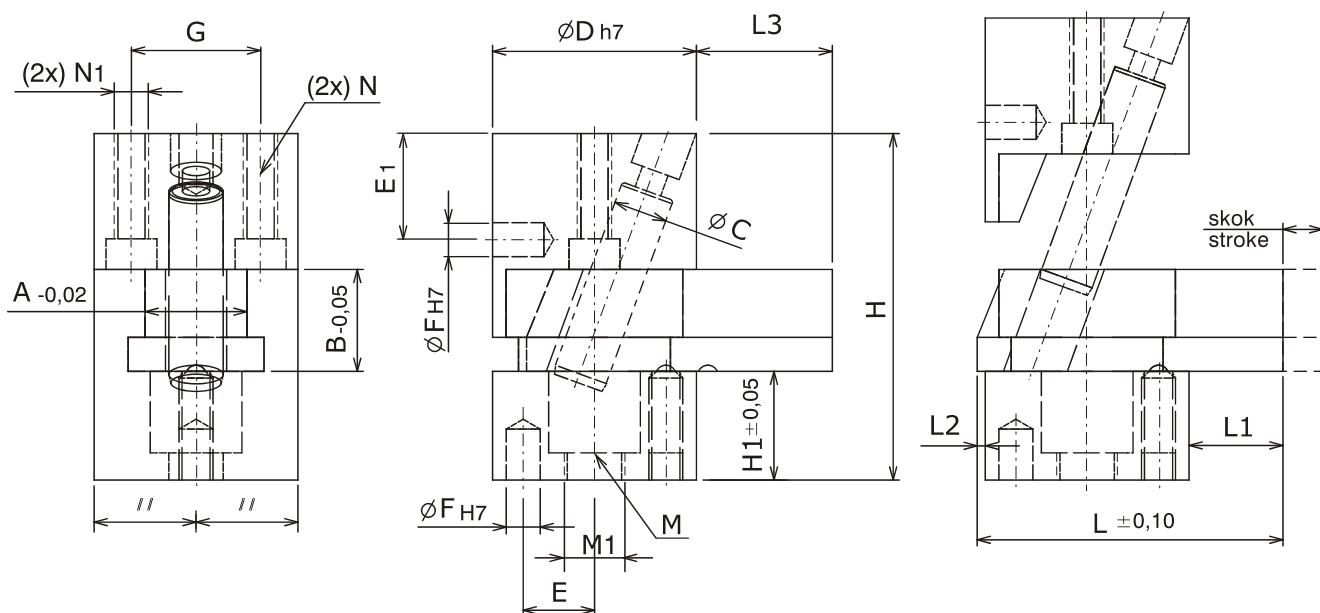

NR KAT.	A	B	C	D	E	E1	F	G	H	H1	L	L1	L2	L3	M	M1	N	N1	skok stroke
MS41-22	10	10	$\varnothing 6$	$\varnothing 22$	7,5	11,5	$\varnothing 4_{H7}$	14	34,5	10	35	12,5	0,5	15	M4	M5	M3	M4	2,5
MS41-30	15	15	$\varnothing 8$	$\varnothing 30$	10,5	15,5	$\varnothing 5_{H7}$	19	51	16	45	15,4	----	20	M6	M8	M4	M5	4,6
MS41-35	20	20	$\varnothing 10$	$\varnothing 35$	13	15,5	$\varnothing 5_{H7}$	24	63	23	55,5	17,8	2,7	25	M8	M10	M5	M6	7,2